

THUNDER TIGER PRO.H RING TYPE SERIES ENGINES INSTRUCTIONS



INTRODUCTION

Congratulations on your purchase of a Thunder Tiger model engine. ALL the latest Thunder Tiger series engines have been designed to combine the high performance with easy handling and maintenance using modern CAD computer technology. Major components of the engines are machined from the highest quality materials using state-of-the art CNC manufacturing techniques, resulting in consistently high quality and reliability.

The PRO series helicopter ring type engines are equipped with dual ball-bearings, Schnuerle porting, one ring type piston/cylinder assembly and two-needles automatic mixture control carburetor.

IMPORTANT

This engine will provide you with years of safe use, provided that you carefully follow these safety instructions:

1. This model engine IS NOT A TOY, but a powerful miniature engine that is capable of inflicting damage to both people and property if misused.
2. Always mount the engine securely in a test stand or high-quality engine mount. Never, never attempt to clamp your engine in a vise!
3. Make sure that you use the suitable size engines and rotors for your helicopter that followed the recommend of helicopter instruction manual.
4. Make sure that the installation of the clutch/cooling fan system on the engine is securely fastened and correctly. Unsuitable installation will cause huge vibration during helicopter flying.
5. Do not run your engine around dirt, sand or loose gravel. Such material can be thrown into your eyes by the propeller. In addition, the engine can be damaged by these materials entering the carburetor.
6. Take care to keep all loose clothing, rags, tools, etc. away from the rotors.
7. Take care when handling your engine after running. Model engines get very hot during operation!
8. Always operate your engine with proper ventilation. Model engines produce toxic fumes when run in a closed room or confined area.

SPECIFICATIONS

ENGINE	ITEM NO	Displacement (c.c/cu.in)	Bore (mm/in)	Stroke (mm/in)	Crankshaft Thread	Practical RPM	OUTPUT (BHP/RPM)	Weight (g/oz)
PRO-39H(R)	9604	6.45 / 0.394	21.6 / 0.850	17.6 / 0.693	UNC 1/4-28	2,000~22,000	1.35/18,000	290/10.22
PRO-50H(R)	9605	8.27 / 0.504	22.5 / 0.886	20.8 / 0.819	UNC 1/4-28	2,000~20,000	1.75 / 17,000	405/14.28
PRO-70H(R)	9607	11.49 / 0.701	25 / 0.984	23.4 / 0.921	UNC5/16-24	2,000~18,000	2.25 / 16,000	570/20.10
PRO-90H(R)	9609	14.78 / 0.902	28 / 1.102	24 / 0.945	UNC5/16-24	2,000~16,000	2.75 / 15,000	575 / 20.28

INSTALLATION

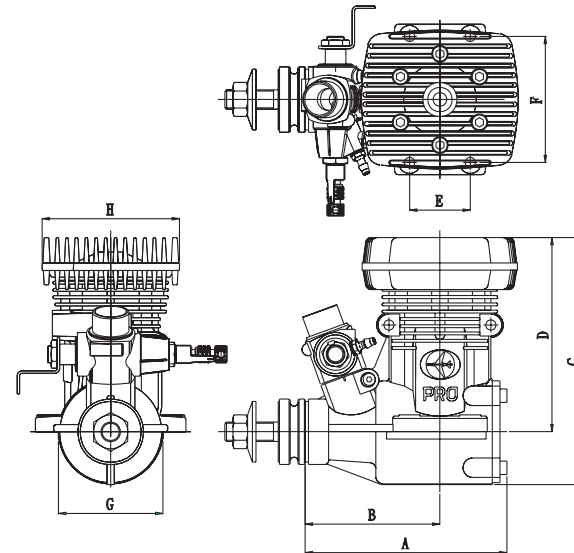

■ Engine

Mount your engine securely to rigid engine mount. Make sure the mounting surface are absolutely flat and parallel to avoid engine distortion (bearings, crankcase...) and power loss.

■ Dimensions

ENGINE	A (mm/in)	B (mm/in)	C (mm/in)	D (mm/in)	E (mm/in)	F (mm/in)	G (mm/in)	H (mm/in)
PRO-39H(R)	74.5/2.93	53.0/2.09	76.8/3.02	61.0/2.40	15.0/0.59	38.0/1.49	31.0/1.22	43.4/1.709
PRO-50H(R)	84.9 / 3.343	60.3 / 2.374	86.4 / 3.402	69.1 / 2.72	17.5 / 0.689	44 / 1.732	34.0/1.34	45.6/1.795
PRO-70H(R)	83.1 / 3.272	55.5 / 2.185	101.9 / 4.012	80.1 / 3.154	25 / 0.984	52 / 2.047	43.0/1.69	56.6/2.228
PRO-90H(R)	83.1 / 3.272	55.5 / 2.185	102.3 / 4.028	80.5 / 3.169	25 / 0.984	52 / 2.047	43.0/1.69	56.6/2.228

NECESSITIES

The following items are necessary for operating the engine, these are available at you hobby dealer.

■ FUEL

A good quality, commercially available fuel containing 25% lubricant and 75% methanol is recommended for break-in /run-in and general usage. We also recommend castor oil or a castor /synthetic blend only for use as a lubricant. Fuel containing 5%~30% nitromethane and 20% lubricant is for use when more power is required. Most fuels containing synthetic lubricants (only) are much less tolerant of a lean run compared to fuel that contains castor oil. If availability or local conditions force you to use a fuel that contains only synthetic lubricant, we suggest that you keep your needle valve set to a slightly richer setting, allowing more lubricant to flow through your engine to extend engine life and maintain optimum reliability. Do not use fuel containing less than 20% lubricant.

CAUTION 1

Methanol and nitromethane are poisonous and highly flammable. Keep out of reach from small children and keep away from heat and open flame.

CAUTION 2

Excessive heat can greatly reduce the life of your engine. Most of the heat generated by combustion is removed via the lubricants that are contained in your fuel, and exits the engine as exhaust vapor. As a precaution, you should periodically remove the muffler from your engine and visually inspect the exhaust port and piston. If the outer surface of the piston is stained a very dark color, it can indicate that your engine may be overheating. This can be caused by either an excessively lean needle setting or a lack of airflow across the cylinder and head.

■ GLOW PLUG

The type and quality of glow plug used in your engine will have a major impact on overall performance and reliability. The engine operates best with a R/C long-type plug such as Thunder Tiger, K&B, or O.S.No.8. Fox plugs (while of excellent quality) have a colder heat range and may cause idle or throttle transition problems in small engines.

■ BREAK-IN/RUN-IN

Because Thunder Tiger engines are precision-made from quality materials and is a ringed engine, prolonged break-in is not required.

But, when it is new, the engine must be run in a rich condition for at least 6 tanks of fuel to allow for proper break-in. It is important to make sure the engine does not overheat at anytime. Also, it is critical that the engine be run in an area free from excessive dirt and sand.

CARBURETOR ADJUSTMENT

The Thunder Tiger PRO.H type carburetors are specially designed for the high performance Thunder Tiger PRO series helicopter engines and provide the proper air-fuel mixture automatically for helicopter flying at any throttle operating range.

Since the carburetor has been pre-set at the factory, large adjustments of this carburetor should not be required. However, under different operating conditions, minor re-adjustments may be required. These conditions include set-up of the helicopter, glow plug used, and weather conditions.

■ IMPORTANT

Before trying to adjust the carburetor, please note the following. In helicopters, engine failure in flight as a serious problem, especially for the inexperienced modeler. It can mean loss of control and a resulting crash.

For ensuring safe and reliable control on the helicopter flight, it is a must that the engine keeps running and that the throttle has quick and reliable response. Therefore, the carburetor adjustment is very important for the helicopter and this should be done with great care to obtain an optimum throttle response. In the helicopter flight, the throttle response on the medium speed range with the partial throttle opening is very important. Because, medium speed range is widely used in the flight. On this carburetor, only two adjustable controls are provided.

- 1) Needle Valve (installed in left hand side of carburetor) This controls the mixture strength of the engine speed range from half to fully opened throttle.
- 2) Mixture Metering Screw (hidden in the throttle barrel in right hand side). This controls the mixture strength of the speed range from idling to half opened throttle.

Please note the best mixture strength around half opened throttle is obtained with the balanced controls of both 1) Needle Valve and 2) Mixture Metering Screw.

■ SETTING BEFORE ENGINE STARTING

Close (turn clockwise) the Needle Valve until it stops. Open the

Needle Valve 3 turns from the closed position.

Make sure that the throttle linkage is set so that the throttle rotor is fully open when the transmitter throttle stick is moved to full high speed position and that the throttle rotor is fully closed when both the throttle stick and throttle trim lever are moved to the lowest position.

■ ADJUSTMENT

Following procedures are recommended to adjust the carburetor. Adjustment low speed performance (range from idle to 1/3 opened throttle)

- 1) Start the engine with the transmitter throttle stick fully down and the throttle trim level set the neutral position.
- 2) Set the throttle trim lever so that the engine runs with highest idling rpm but without engaging the clutch.
- 3) Increase the engine speed by advancing the transmitter throttle stick gradually until the helicopter just lifts up (floats) from the ground. Warm up the engine by keeping above floating condition for approximately 10 seconds then slowly reduce the engine speed, land, and allow the engine to idle for a while.
- 4) Repeat above procedure several times. If the engine tends to hesitate or stop after hesitation, the mixture at idle is not correct. Generally speaking, if the mixture at the idle is too rich, the engine stops abruptly with short hesitation when the throttle is opened. On the other hand, if the mixture is too lean, the engine will hesitate a little longer with weakened exhaust sound.
- 5) If the engine runs with hesitation but does not stop then try to increase the engine speed by means of the transmitter. Try to hover the helicopter, maintaining the altitude of approx. 1 ft or 30 cm from the ground, then carefully watch the exhaust smoke. If the mixture is too rich, you may observe an excess of exhaust smoke and will feel lazy throttle response. If the mixture is too lean, the engine runs with higher pitched exhaust sound, without any or very low exhaust smoke then the speed will be reduced showing overheating tendency and the helicopter is hard to continue hovering.
- 6) After you find the condition of the mixture, turn the Mixture Metering Screw 30 degree at a time, according to the mixture, by using a small screw driver to correct the mixture. If it is too rich, turn the screw clockwise. If it is too lean, turn the screw counter-clockwise.

● Adjustment high speed performance

The optimum Needle Valve setting is usually 1/4~1/2 turn closed from the starting position (i.e 3 turns open from the fully closed position). It depends, of course, on 1) the individual characteristics of the helicopter and its engine/muffler installation, 2) the fuel used and 3) atmospheric conditions.

The Needle Valve should be gradually closed until the highest performance is obtained in flight at full power.

However, take care not to close the Needle Valve to a too lean setting and risk overheating the engine, in the pursuit of maximum performance.

● Adjustment middle range performance

As previously stated, in helicopter flight, throttle response at medium (hovering) speeds is most important. If the Mixture Metering Screw (low speed) and Needle Valve (high speed) are properly balanced, the mixture will be correct, through the medium speed range.

If, however, minor re-adjustments prove to be necessary for the best possible throttle response, proceed as indicated by the following symptoms and required corrective action:

- 1) If the mixture at middle range is lean, gradually increased engine speed is accompanied by diminished exhaust smoke and a high-pitched exhaust sound if hovering is prolonged. In extreme cases, the engine will overheat and lose speed, so that hovering cannot be maintained. In this event, open the Needle Valve 15 to 30 degrees and turn the Mixture Metering Screw 30 to 45 degrees counter-clockwise.
- 2) If the mixture at middle range is too rich, positive and quick throttle response will not be obtained, the exhaust smoke will be dense and the exhaust sound will be lower, probably accompanied by fuselage vibration. In this event, close the Needle Valve 30 to 60 degrees and turn the Mixture Metering Screw 45 to 90 degrees clockwise.

Note: It is most important to make the Needle Valve adjustment in small increments of not more than 15 to 30 degrees and the Mixture Metering Screw adjustment not more than 30 to 45 degrees as advised, when seeking optimum middle range throttle response. Excessive re-adjustment will upset either low speed performance or high speed performance. Carry out re-adjustments patiently until the best balance of idling, hovering and high speed performance is achieved and the engine responds quickly and positively to the throttle control. Throttle response at hovering speeds is also affected by the relationship of the main rotor pitch angle to throttle opening. If the optimum middle range, throttle response cannot be obtained by the carburetor adjustments described above, try adjusting the helicopter's pitch control characteristics.

ENGINE CARE

Always keep the outside of your engine clean. Use clean, fresh fuel and keep your fuel can, pump, and fueling system free from dirt particles. Install a fresh fuel filter between the fuel tank and carburetor, and between your fuel pump and filling line to prevent any potential of dirt entering your engine. Model fuel contains alcohol, which is hygroscopic (meaning that it attracts moisture from the atmosphere). This can cause corrosion to the internal engine parts. After each flying session, run all the fuel out from inside the engine and disconnect the fuel line from the carburetor. Put 4 or 5 drops of after-run oil (Marvel Mystery Oil, Prather, Pacer, etc.) into the carburetor and turn the propeller over by hand several times to protect the engine bearings and internal parts from corrosion. The use of after-run oil is also important during periods of prolonged storage (such as winter). We suggest removing the engine from the model, and liberally applying oil into the carburetor and glow plug hole, wrap your engine in a soft cloth and store in

a sealed plastic bag.

Do not dismantle your engine unnecessarily, as this may upset precision fits. If it is necessary to clean your engine completely (such as after a crash), remove only the needle valve assembly and venturi carburetor, muffler, backplate, and cylinder head. Flush the entire engine with fresh fuel and reassemble.

On the piston/ring set, there is a small pin in the piston ring groove to fit the ring. If you have to dismantle the piston/ring from the engine, you must take care the position of the pin. When you re-install the piston, you should follow the original setting. Incorrect installation of the piston/ring will cause serious damage of the engine. Apply after-run oil to the engine and store or re-install into the model. Do not disassemble your engine further than described above, or your warranty may be voided!

INSTALLATION OF THE PISTON

There is a point mark on the piston top surface. When you reassemble the engine, this mark should be toward the front of the engine as you install the piston. If the direction is not correct, the piston ring would be stuck with the ports on cylinder.

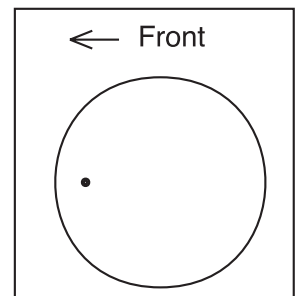

WARRANTY

Your engine is guaranteed to be free from defects in materials and workmanship for a period of 3 years from the date of purchase when returned for service accompanied by proof of purchase (register receipt, credit card invoice, etc.). Crash damage or problems caused by improper use are specifically not covered under this warranty. Damage caused by customer disassembly, use of improper or substandard fuel, use of improper accessories (such as propellers, glow plugs, etc.) or any use of the product other than its specific intended use will automatically void this warranty.

SERVICE PROCEDURES

Should your Thunder Tiger engine require service, please follow the following guidelines:

1. Do not return the engine to the place of purchase, as they are not authorized or equipped to perform service.
2. Remove the engine from the model. We cannot accept equipment for service other than the engine.
3. Along with your engine and proof of purchase, enclose a complete written explanation detailing the problem(s) with your engine. Be sure to include your name, address and daytime telephone number.
4. For repairs not covered under warranty, the charges will be billed to you C.O.D. Please mention if you wish to have an estimate of non-warranty repair charges prior to us beginning service. (This may cause a slight delay in your repair.)
5. For customers outside of the U.S. and Canada, contact the authorized Thunder Tiger agent in your country.
6. For U.S. and Canadian customers, send your engine via insured mail or U.P.S. to ACE HOBBY DISTRIBUTORS INC., 2055 Main Street, Irvine, CA 92614

PARTS LIST / ENGINE

No.	Description	9604 PRO-39H(R)	9605 PRO-50H(R)	9607 PRO-70H(R)	9609 PRO-90H(R)
1	PROP NUT	AA0025B	AA0025B	AML5/16B	AML5/16B
2	PROP WASHER	AA0026B	AA0026B	AA0280B	AA0280B
3	DRIVE WASHER SET	AA0221	PN0023	PN0118	PN0118
4	CRANKSHAFT	AA0792	AA0740	AA0910	AA0902
5	CRANKCASE	AN0969	AN0739	AN0911	AA0901
6	BACKPLATE	AA0224	AA0324	AA0909	AA0909
7	CONNECTING ROD	AN0964	AN0325	AN0285	AN0905
8	WRIST PIN ASSEMBLY	AA0337	AA0337	AA0917	AA0489
9	CIRCLIP	AA0327	AA0327	AA0287	AA0513
10a	PISTON	AN0966	AN0273	AN0914	AN0906
10b	PISTON RING	AA0967	AA0274	AA0916	AA0908
10c	CYLINDER	AA0965	AA0272	AA0915	AA0907
11	CYLINDER HEAD	AA0968	AA0743	AA0912	AA0903
12	GASKET SET	PN0221	PN0192	PN0193	PN0194
13	CARB RETAINING BOLT	PN0220	AN0275	AN0781	AN0781
15	CARBURETOR ASSEMBLY	9204N	9239N	9294	9266
16a	BALL BEARING, FRONT	AMV699Z	AMV1438Z	AMV1438Z	AMV1438Z
16b	BALL BEARING, REAR	AMV6901	AMV690Z	AMV16003	AMV16003
17	SCREW SET	PN0222	PN0116	PN0003	PN0003

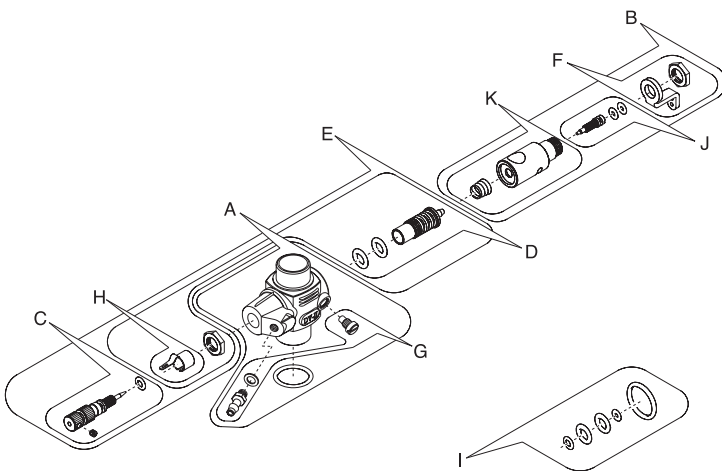
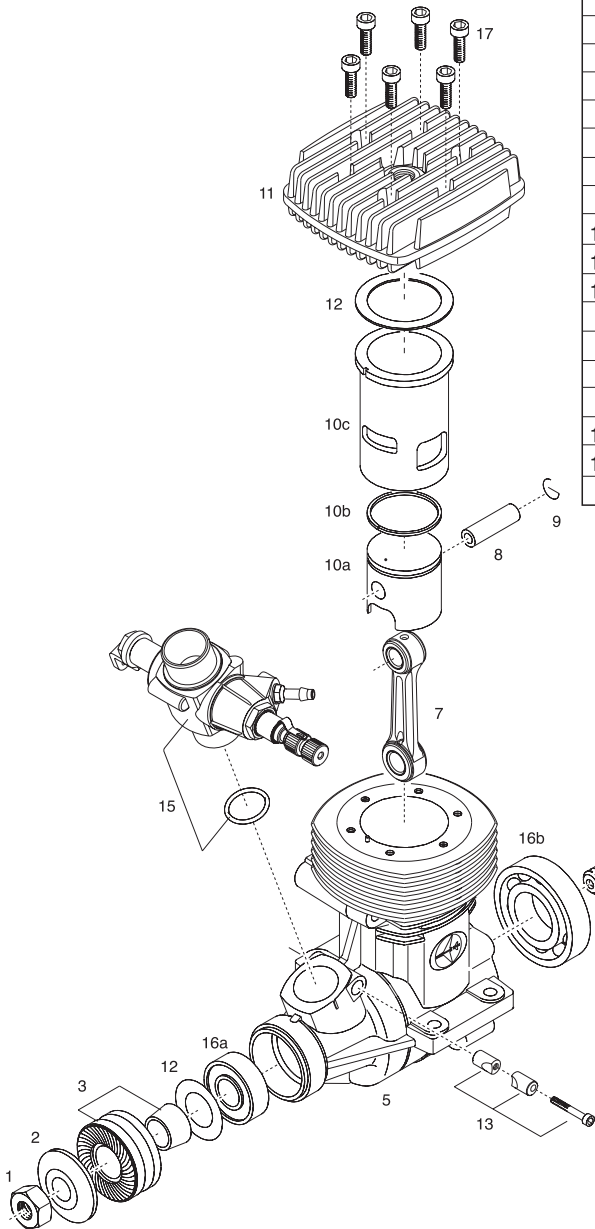

PARTS LIST / CARB

DISCRIPTION OF PARTS	9204N	9239N	9294	9266
A CARBURETOR BODY	PN1263	PN1181	PN1200	PN1254
B CARB. ROTOR ASSY	PN1205	PN1205	PN1201	PN1255
C NEEDLE VALVE ONLY	PN1264	PN1173	PN1173	PN1173
D SPRAY BAR ASSEMBLY	PN1273	PN1273	PN1185	PN1185
E NEEDLE VALVE ASSY.	PN1274	PN1274	PN1186	PN1186
F THROTTLE LEVER	PN1102	PN1102	PN1102	PN1102
G BOLT&FUEL INLET	PN1007	PN1007	PN1007	PN1007
H RATECHET SPRING	AA1025B	AA1025B	AA1025B	AA1025B
I O RING SET	PN1202	PN1202	PN1202	PN1202
J MIXTURE METERING SCREW SET	PN1265	PN1206	PN1203	PN1203
K THROTTLE ROTOR SET	PN1266	PN1207	PN1204	PN1256



Manufactured by Thunder Tiger Corporation

No. 7, 6Th Road Industry Park Taichung, Taiwan R.O.C. 407

Tel:886-4-23591616 Fax:886-4-23591902

Website: www.thundertiger.com E-mail:tiger99@ms2.hinet.net

Distributed In North America by Ace Hobby Distributors, Inc.

2055 Main Street, Irvine, CA 92614, USA Phone: 1-949-833-7498

Website: www.acehobby.com E-mail: service@acehobby.com