

Name: _____

Date: _____ Event: _____

City: _____ State: _____

Track: _____

Track Conditions Indoor Tight Smooth Hard Packed Blue Groove Wet Low Bite High Bite
 Outdoor Open Rough Loose/Loamy Dry Dusty Med Bite Other _____

Front Suspension

Toe: _____

Ride Height: _____

Camber: _____

Caster: _____

Sway Bar: _____

Piston/Oil: _____

Spring: _____

Limiters/Droop: _____

Overall Shock Length: _____

Steering Ackerman: _____

Bump Steer: _____

Camber Link: _____

Shock Location: _____

Receiver Battery Type: _____

Differentials

Front: Standard Smart

Spring Wire Dia: _____

Qty of Springs: _____

Ramp Plate: _____

Grease: _____

Diff Fluid: _____

Center: Standard Smart

Spring Wire Dia: _____

Qty of Springs: _____

Ramp Plate: _____

Grease: _____

Diff Fluid: _____

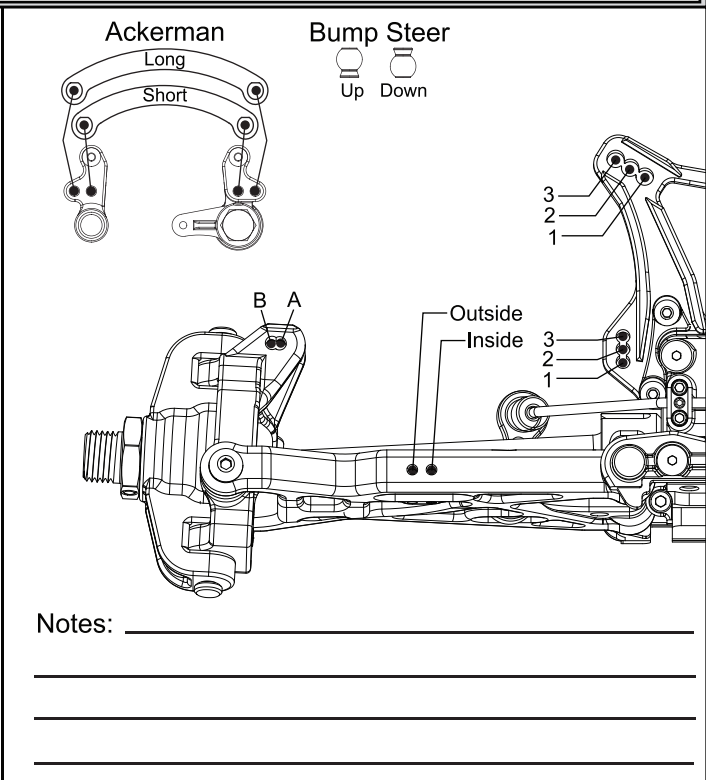

Rear Suspension

Toe: _____

Anti-Squat: _____

Ride Height: _____

Camber: _____

Rear Hub Spacing: _____

Sway Bar: _____

Piston/Oil: _____

Spring: _____

Limiters/Droop: _____

Overall Shock Length: _____

Camber Link: _____

Shock Location: _____

Rear Diff Fluid: _____

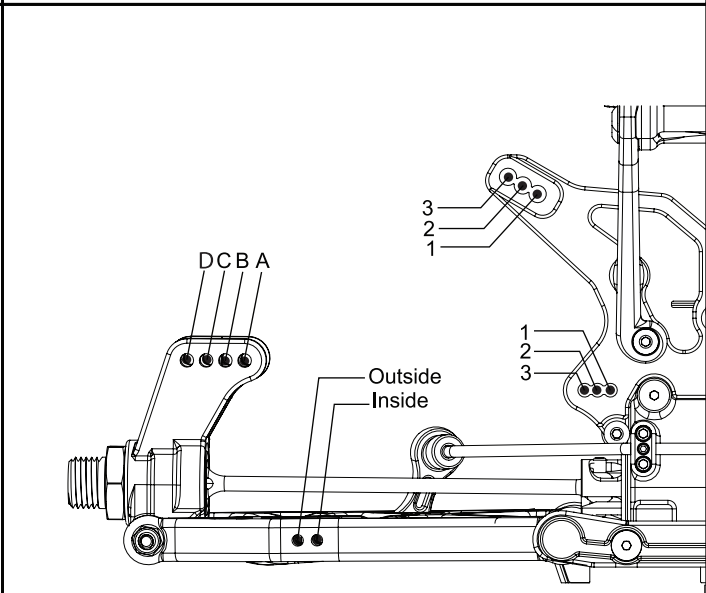

Engine

Engine: _____ Fuel: _____

Glow Plug: _____ Head Clearance: _____

Pipe/Header: _____ Gearing: _____

Clutch

Clutch Shoes and Springs Info

Tires

Type	Compound	Insert
Front: _____	_____	_____
Rear: _____	_____	_____
Notes: _____	_____	_____