

Tsunami 36-54-72-108 Controllers for Brushless Sensorless motors

The plug and play drive sets do not need any programming and they can only be programmed with the transmitter only with the PC cable (optional). For plug and play drive sets go to the next page.

User manual - RC-Setup manual.

multiplex transmitters must reverse throttle

mode	A/C type	Brake	Soft start	Over Temp protection	Throttle Down on low voltage	Motor Stall Protection	RPM control	RPM Limitation
1	E-Sailplane	Medium	On	On	On	On	Off	On
2	Motor model	Off	Off	On	On	On	Off	On
3	Heli	Off	On	Off	Off	Off	On	Off
4	Contest mode	Hard	Off	Off	Off	Off	Off	Off
5	Lipo cells 2-5cells							

The setup mode is started when the ESC receives pulses longer than 1.5ms (full throttle) for 5 seconds right after switching on.

- Switch on transmitter , Full Throttle
- Switch on receiver and ESC
- After 5 seconds you'll hear a fading 3 beeps (NiCad/NiMH).
- Move Throttle to off position .Wait until you hear the mode you want to select.
- When you want to use Mode 1, wait until you hear 1 beep. (Mode 2, 2 Beeps - etc...)
- Immediately move stick to the full throttle position wait for 1 beep (storage of - full Throttle and Mode settings).
- Now move the throttle to your desired start position (Normally the OFF position)
- You'll now hear confirmation of Mode (1/2/3/4/5 beeps)
- Stick to full and than 3 fading beeps and confirmation storing of settings.

Lipo mode 5; After programming stick to off position , then wait till correct amount of cells(beeps) is reached, stick to full , wait for confirmation , take battery of

In Heli mode you must set a desired RPM at a desired stick position. The ESC needs to know the max RPM under load. This information is gathered during the first run after setup. The ESC now knows the Maximum RPM and will save this setting. Half of the throttle throw is also half the RPM etc.. (Setting the RPM to high can overload and damage the ESC. Read warranty note)

NOTE: If you wish to change the settings repeat above procedure.

After switching on the ESC you always hear.

- One beep Setup for NiCd- or NiMh-Packs, or
- One beep setup and one beep per LiPo cell (in lipo mode)

When the ESC receives a correct signal from the receiver and the transmitter has the throttle in the off position , you'll hear a activation signal.

An optional PC-interface cable is available from dealers, with this cable more settings are available e.g. fixed timing, hard/medium/soft brake and low-voltage protection. Disable setup through Transmitter .

DATA: Cells : 6 – 16 Cells 6-12 with BEC (2 – 5 Lithium Polymer), **Max. Amps** 36A,54A,72A108A. **Servos** : 4

WARRANTY:

The Tsunami ESC has a 1 year limited warranty against failure.

All modes where the temperature control is disabled are not covered by warranty

Reversed polarity of batteries is also not covered.

If an ESC breaks down we can measure /read out the last settings in the micro-processor so we can tell what mode was used and what were the settings.

Removing the shrink tube or soldering of any nature will also void warranty.

Safety Precautions:

Always read the instruction first supplied with your equipment used in conjunction with this ESC. Always stay clear from a rotating Propeller, rotating propellers can cause great harm, body injury, death or property damage. Never run a motor while holding in your hands always use a Jig or mounting bracket when you want to test run a motor.

Please use common sense.

Check our website <http://www.highendrc.com> for updates and manuals.

Drive sets.

MULTIPLEX TRANSMITTERS MUST REVERSE THROTTLE

High-End Technology RC PLUG AND PLAY JET EDF DRIVE SETS							
part no	Motor	ESC	lipo	BEC	WATTs	Lipo battery 20C	Inside ***trusttube
EDFSET2W	2W	TS54	3	enable	560	3s3300Mah	yes
EDFSET3W	3W	TS36	4	enable	500	4s2100Mah	no
EDFSET4W	4W	TS36	5	disable*	480	5s2100Mah	no
EDFSET2W20	2W-20	TS72	4	enable	700	4s3300Mah	no
EDFSET2W23	2W-23	TS72	5	disable*	900	5s2500Mah	no
EDFSET2W25	2w-25	TS72 **	6	disable*	1150	6s2100Mah	yes
TO DISABLE THE BEC REMOVE THE JUMPER FROM BEC WIRE HARNESS							
TS** BEC can be plugged into the ballance connector from the lipo and you have 2amp BEC							
TS72** Battery cutoff disabled when you see the plane slowing down in flight, then you should land the plane							
**** mount ESC behind motor inside thrust-tube							

If you don't want to put your esc behind the motor inside the thrust-tube use a ESC with 40% extra capacity e.g. use a TS72 for 2W20

Reverse direction of rotation just swap two motor wires connected to the ESC

Always balance lipo's during or after charging.

Connection diagram:

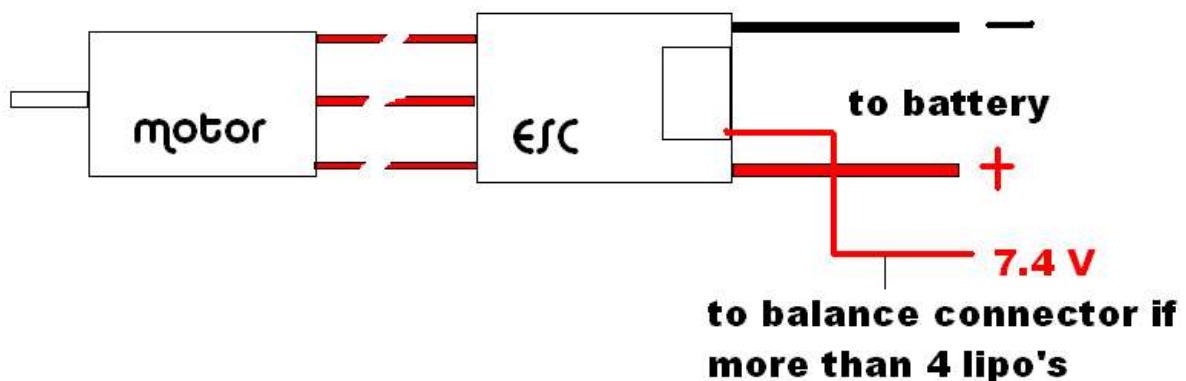

Wire to the balance connector should come from BEC board and connected to 7.4 V on the balance connector, normally this is the third terminal on the connector from the minus side. Check with a volt meter.(Probes on battery-minus connector and terminal of balance connector).

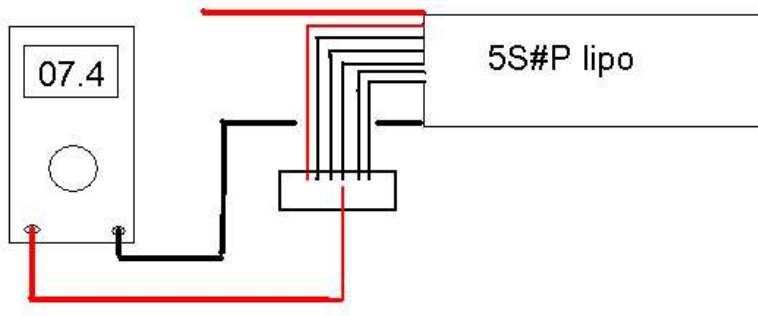

Voltage should be between 7.4 and 8.4 Volt.

ONLY thing need to do is set the **End Point Adjustments** on your transmitter,

IF you want to change the settings you can order our programming cable and download the software from our website.