

# CHANCE VOUGHT F4U-1D Corsair

## RETRACT INSTALLATION

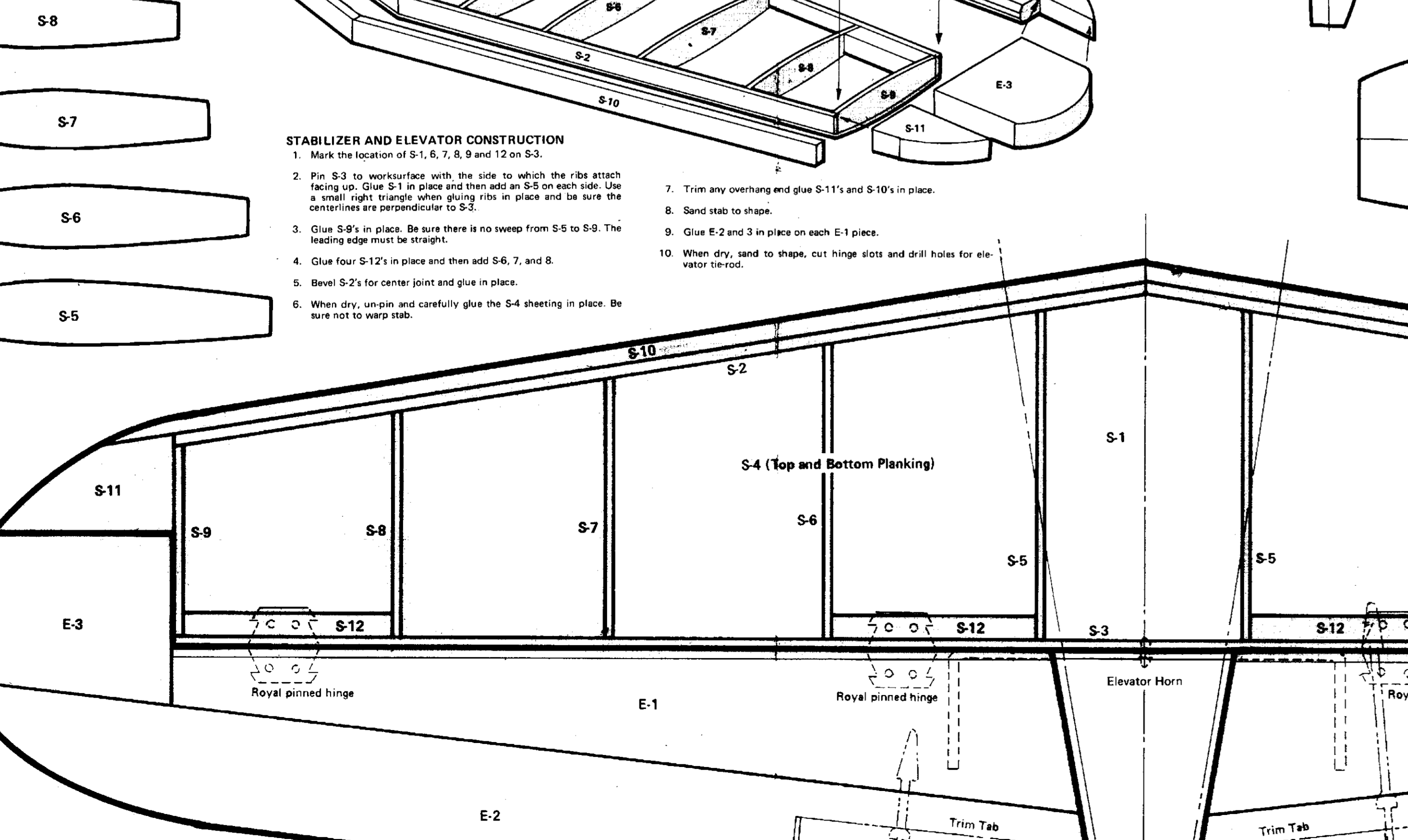

**NOTE TO THE MODELER:**  
All formers and ribs are shown actual size to make "precision" building easier accompanied from these plans, and to facilitate any repairs that may be necessary.

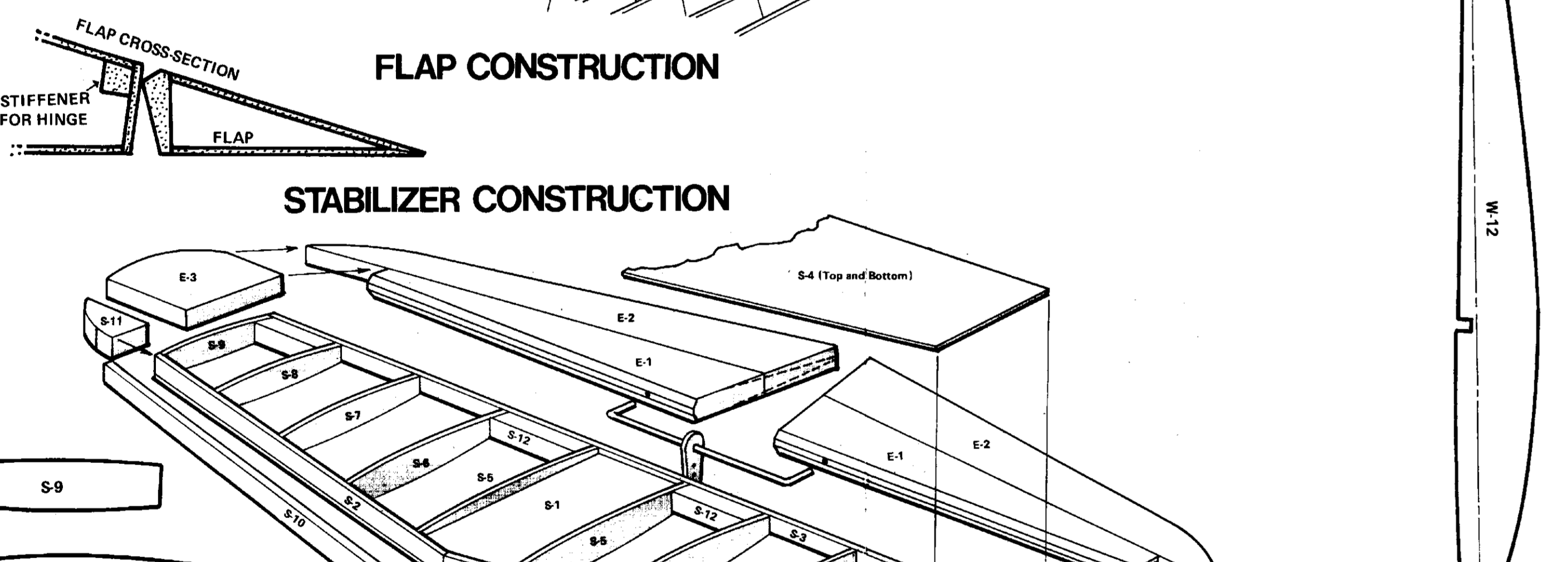
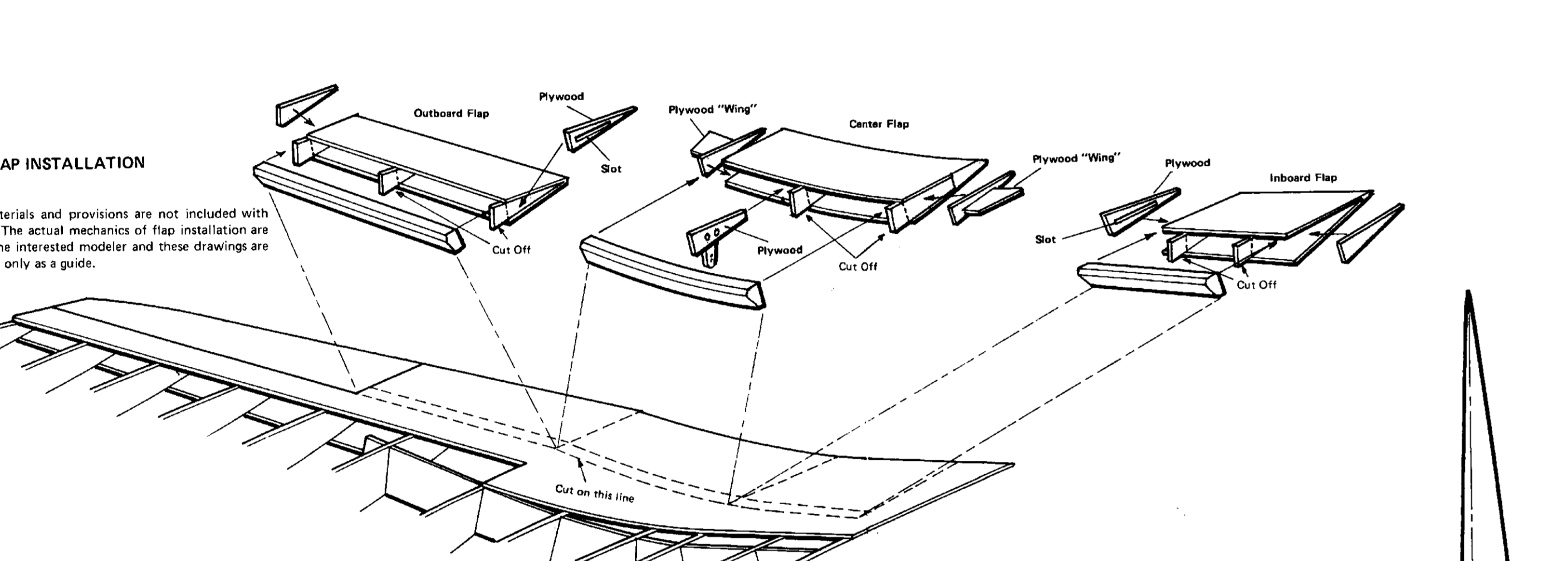
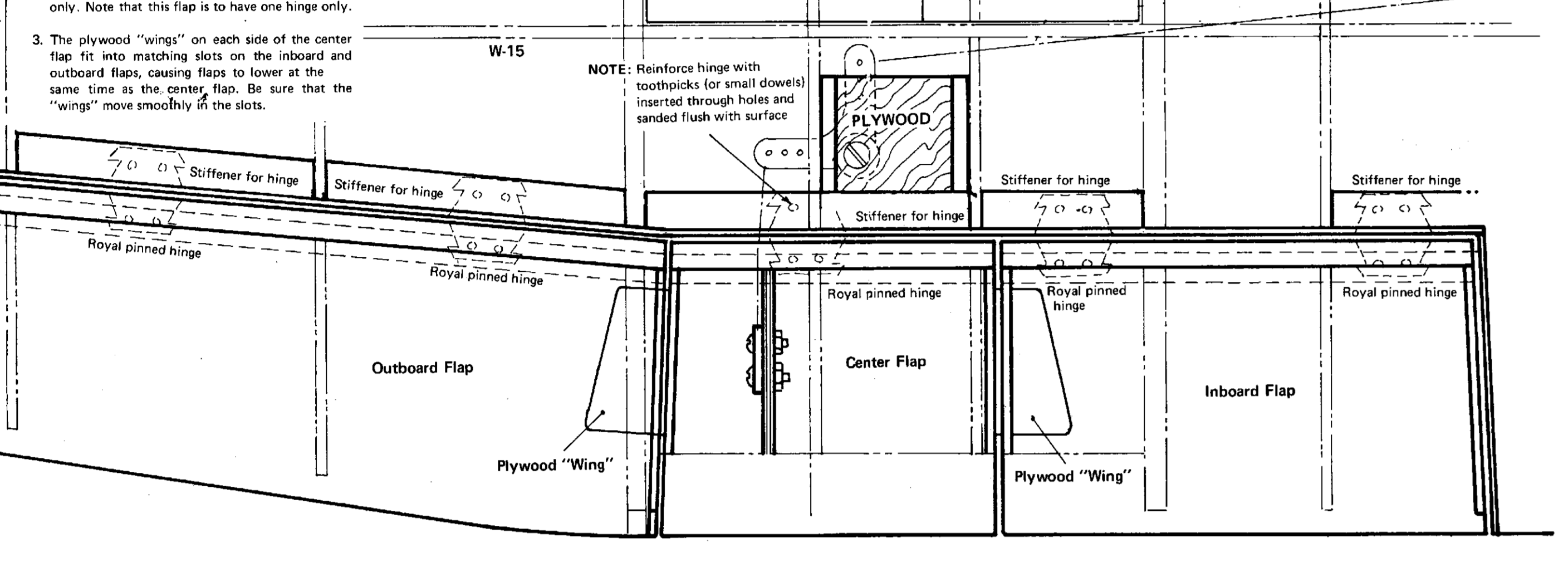
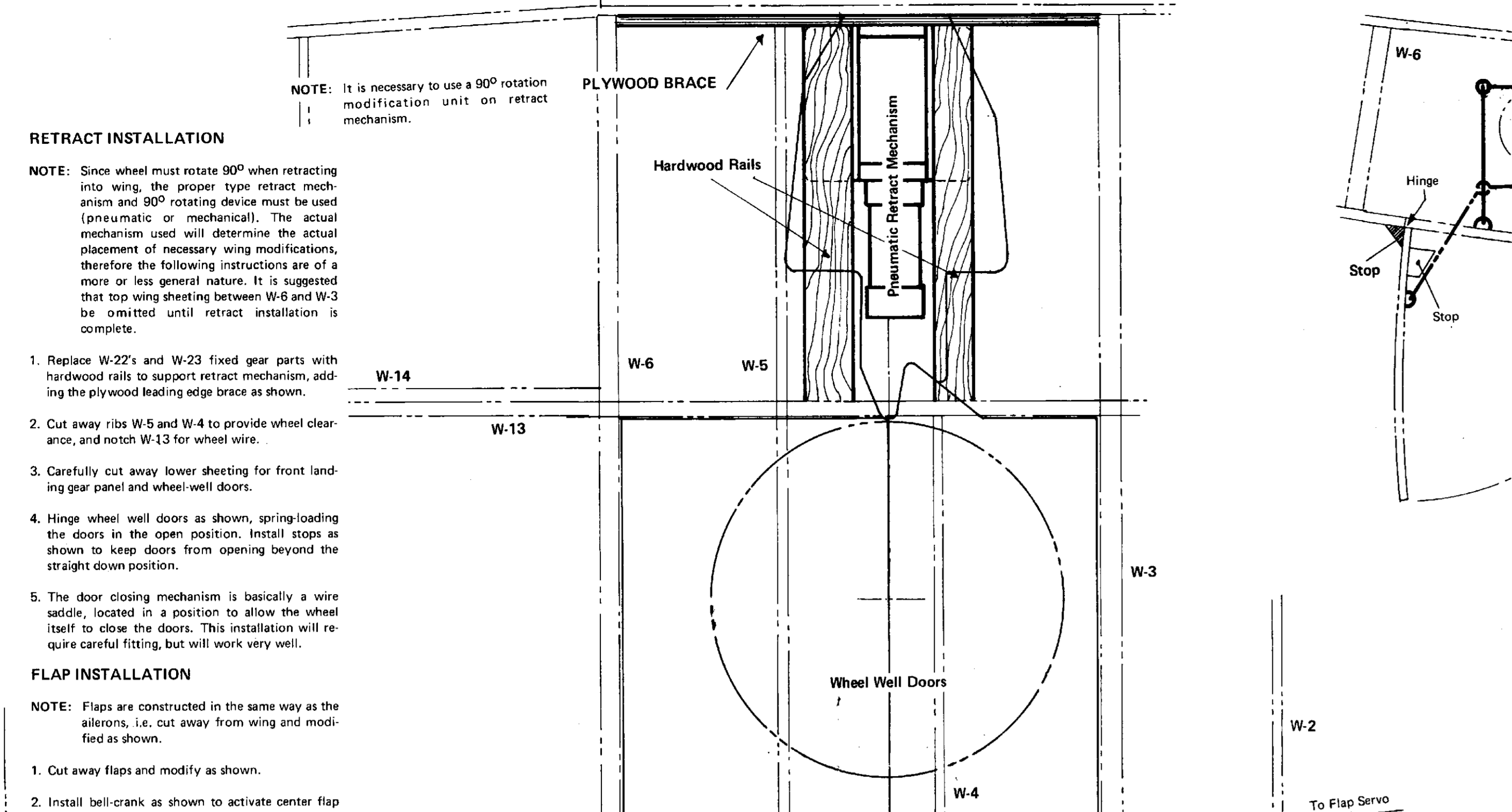
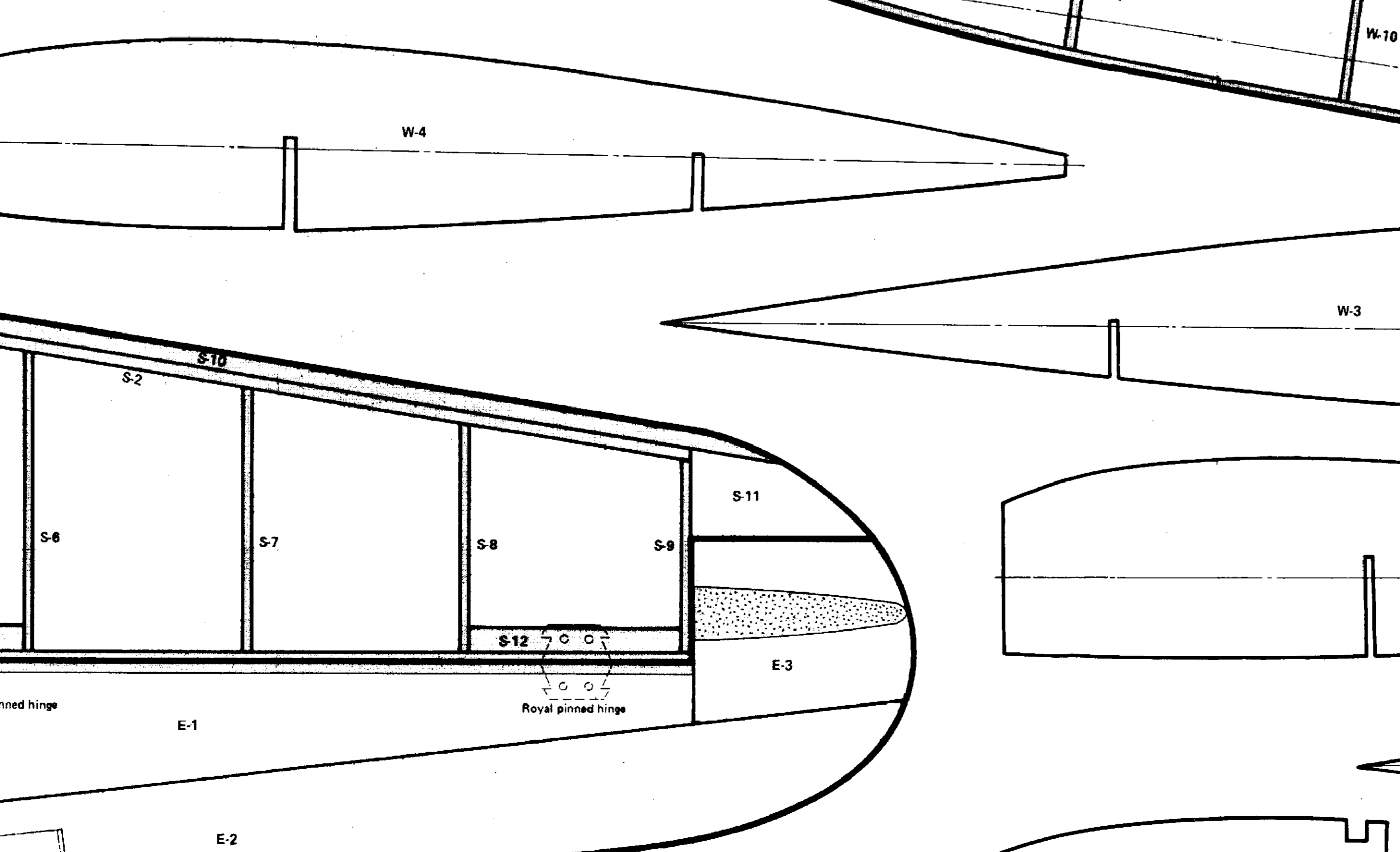
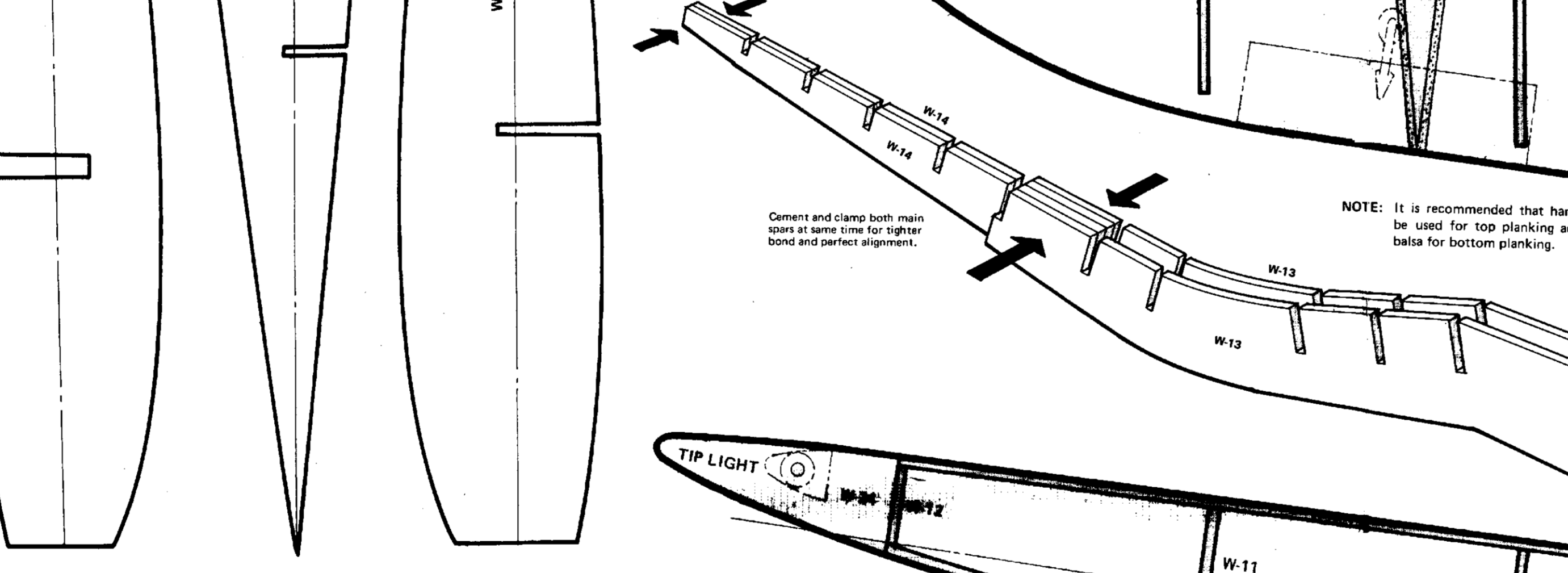
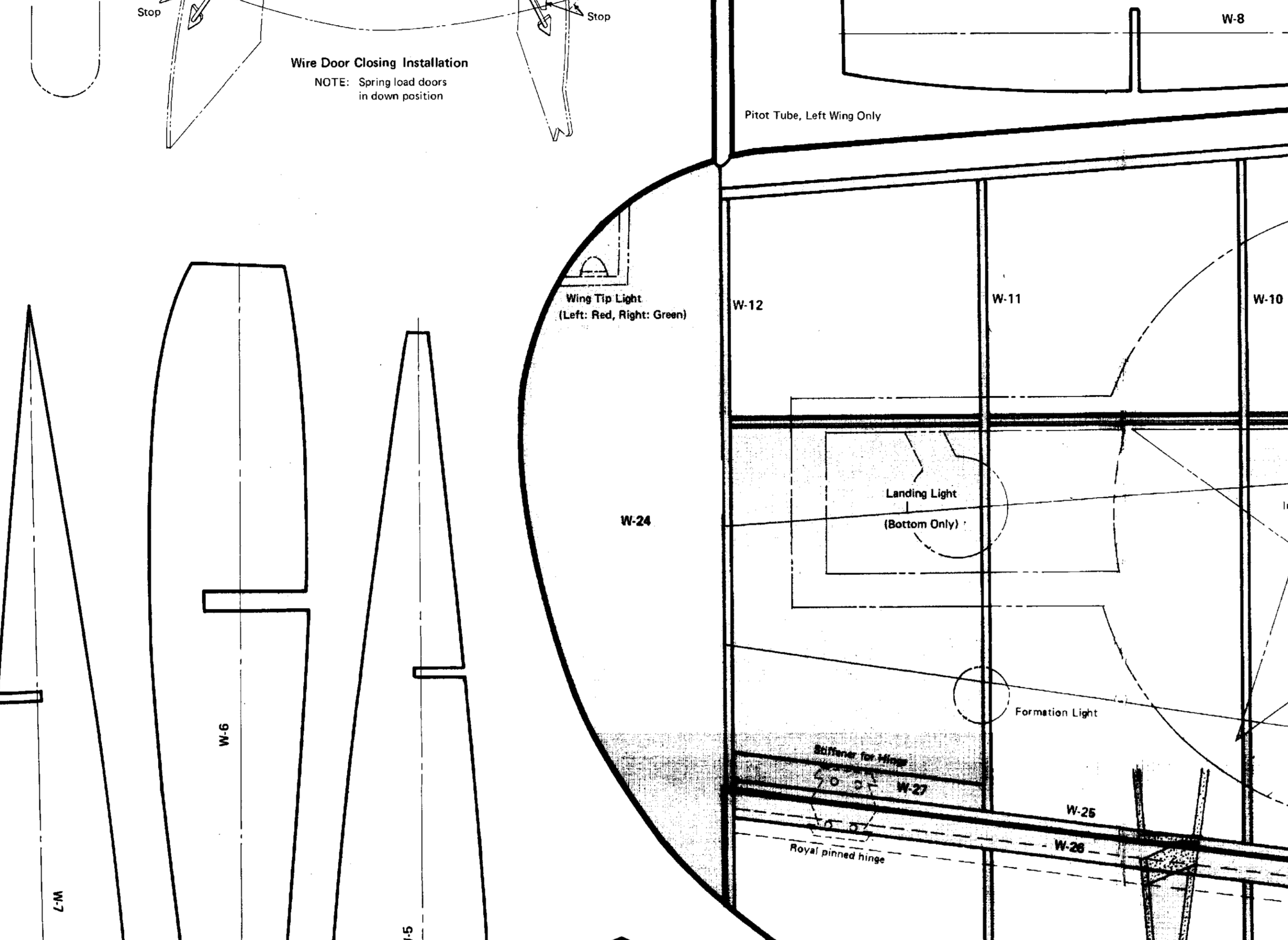
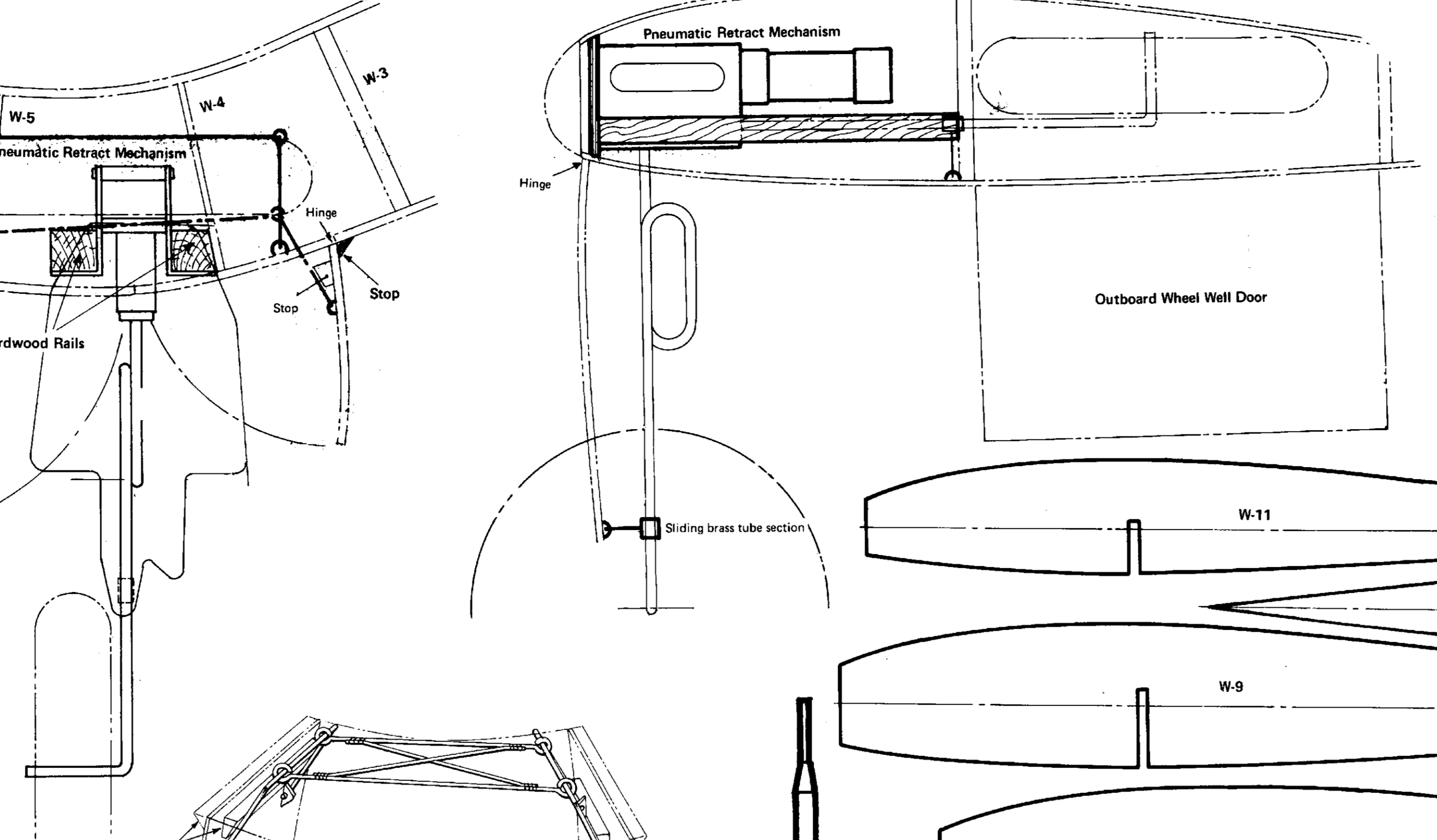

**NOTE TO THE MODELER:**  
All formers and ribs are shown actual size to make "precision" building easier accompanied from these plans, and to facilitate any repairs that may be necessary.

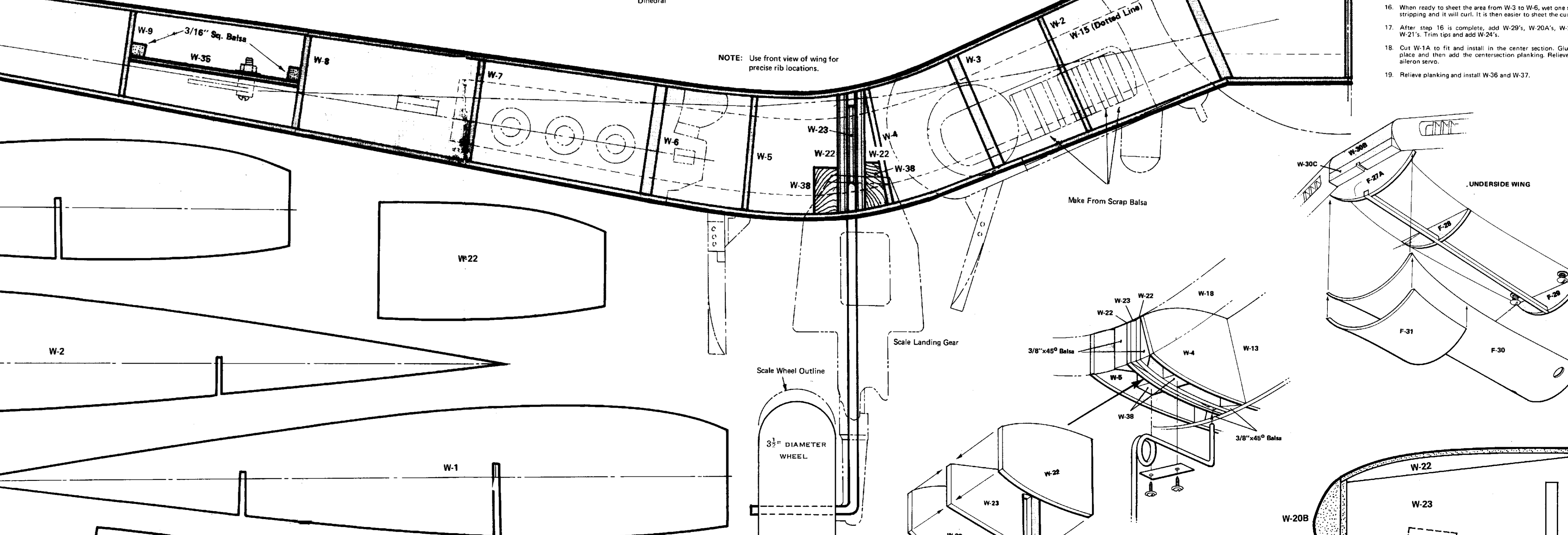
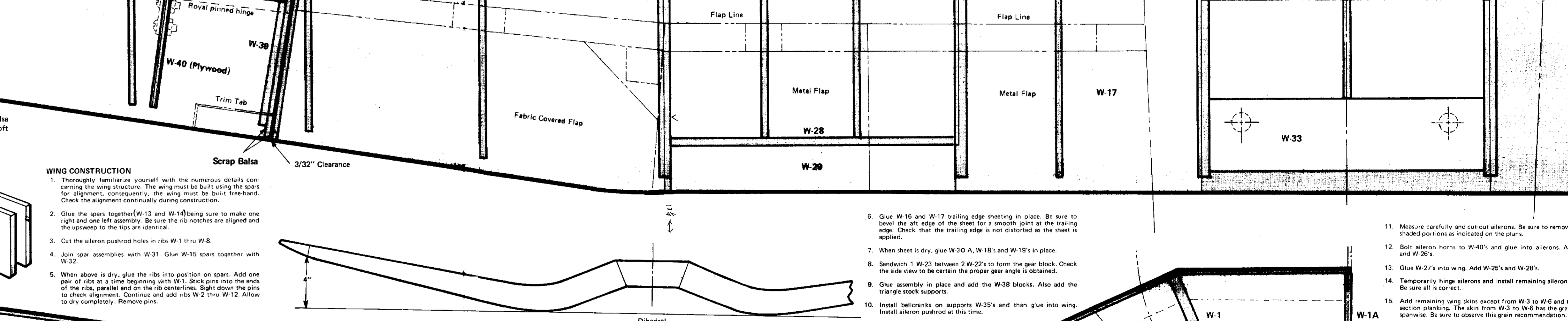
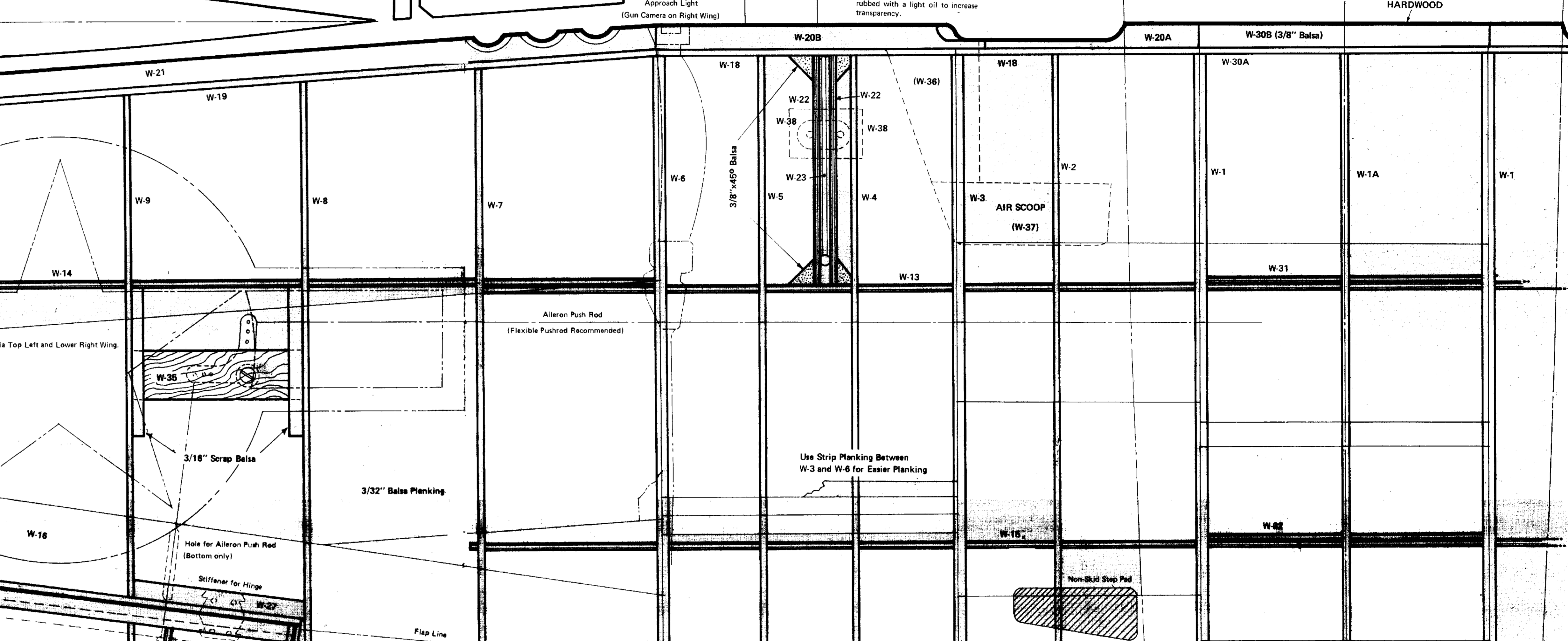
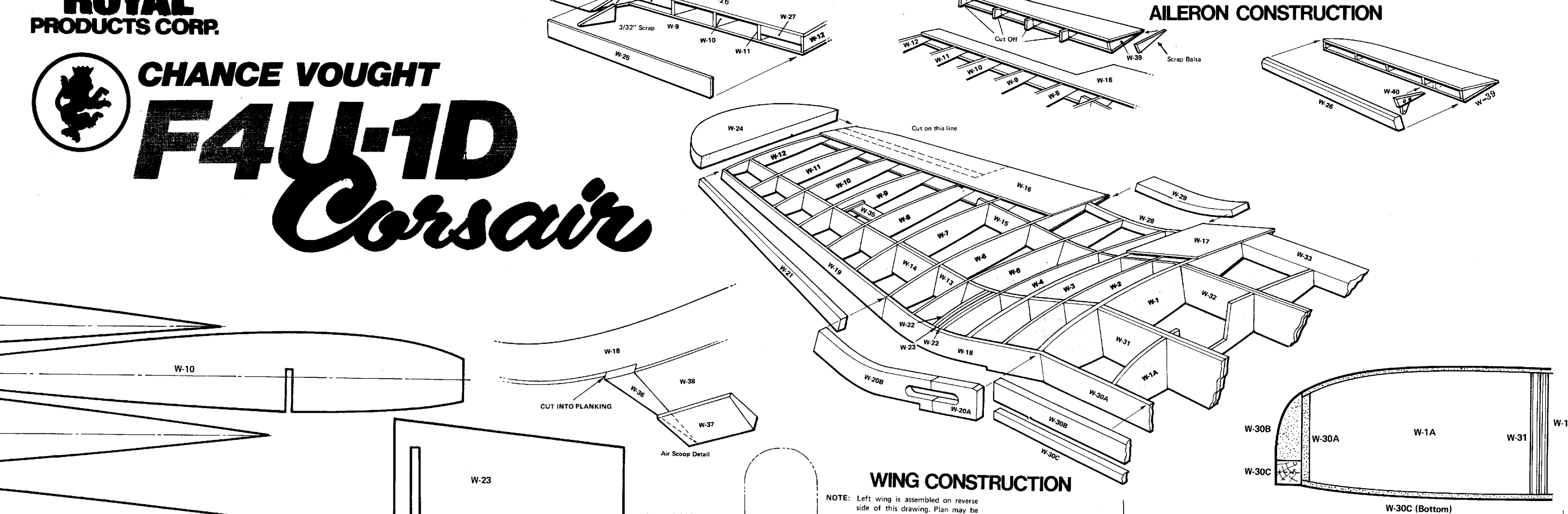

**NOTE TO THE MODELER:**  
All formers and ribs are shown actual size to make "precision" building easier accompanied from these plans, and to facilitate any repairs that may be necessary.

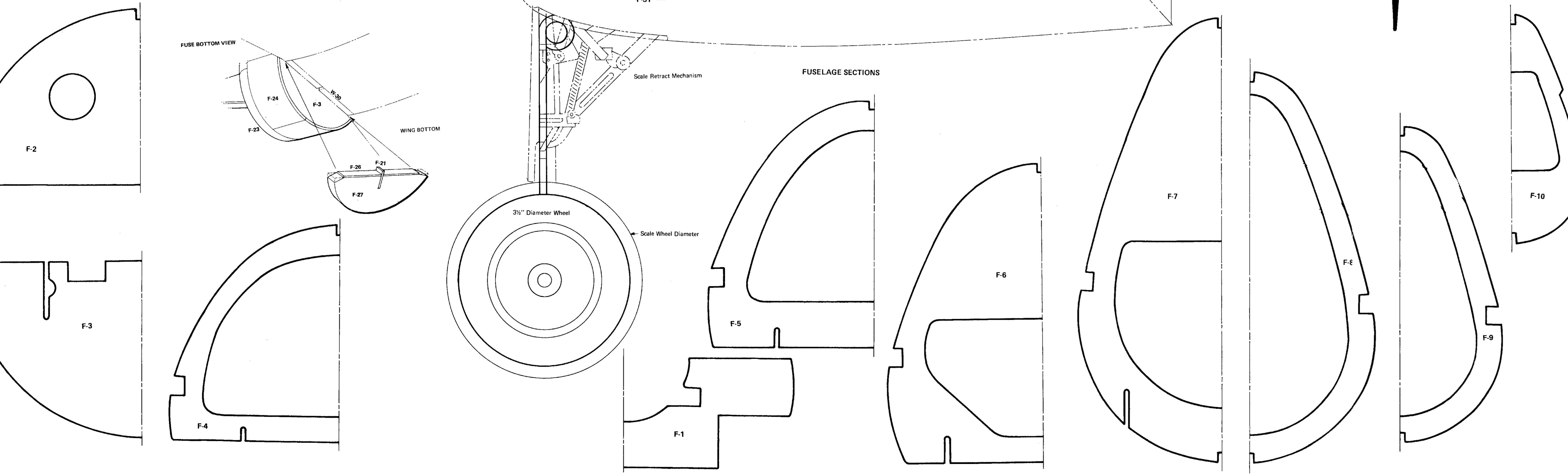

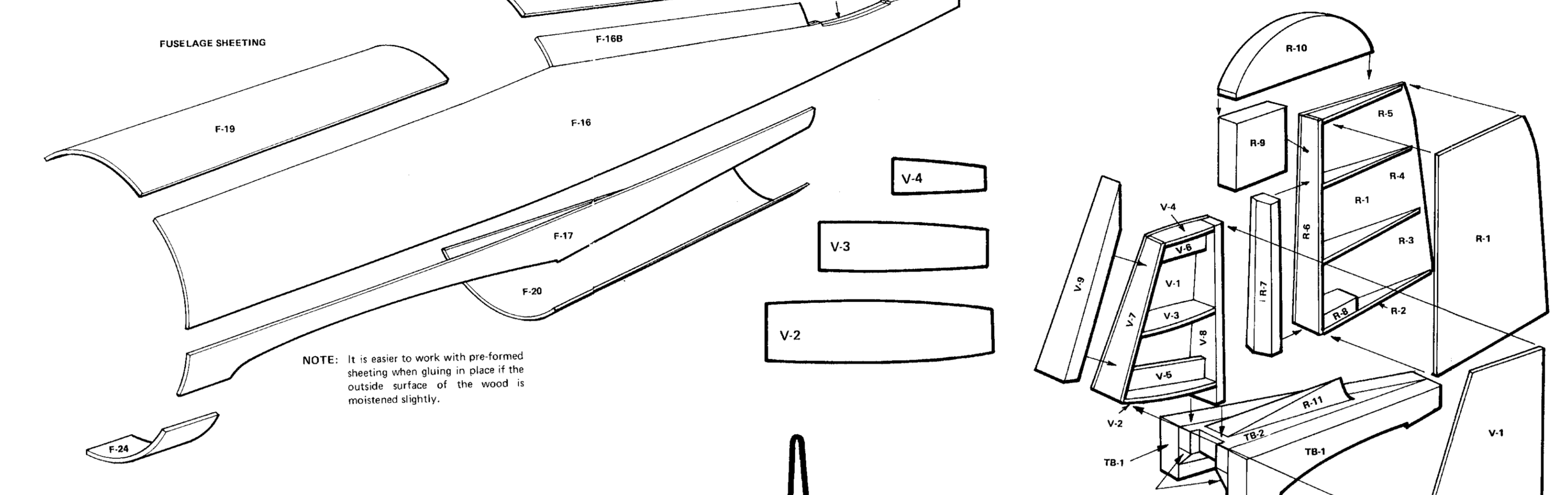
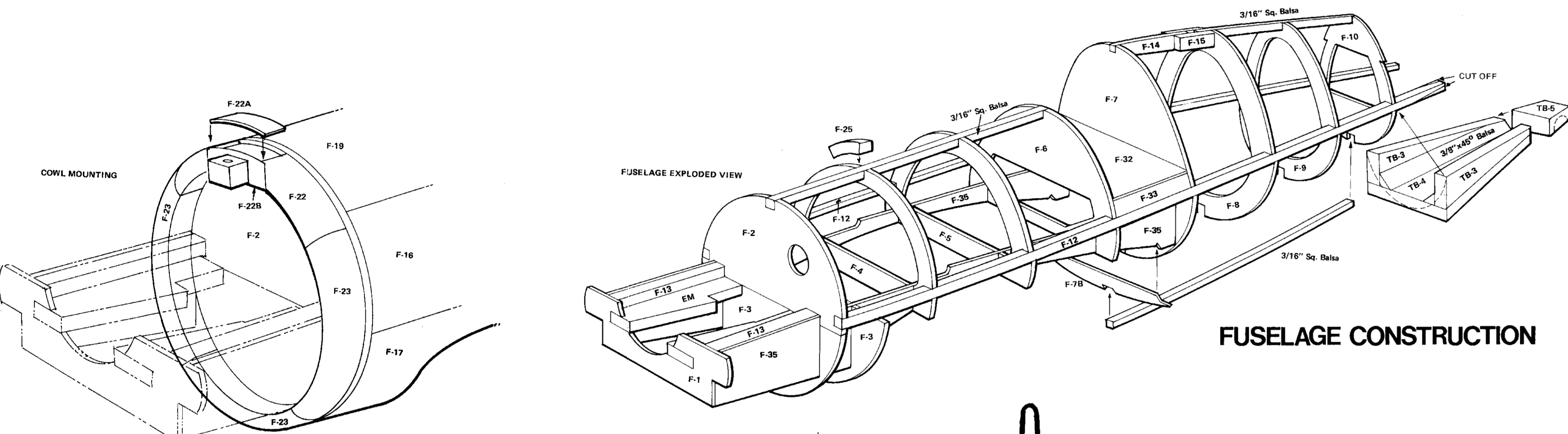


**ROYAL PRODUCTS CORP.**

**F4U-1D Corsair**

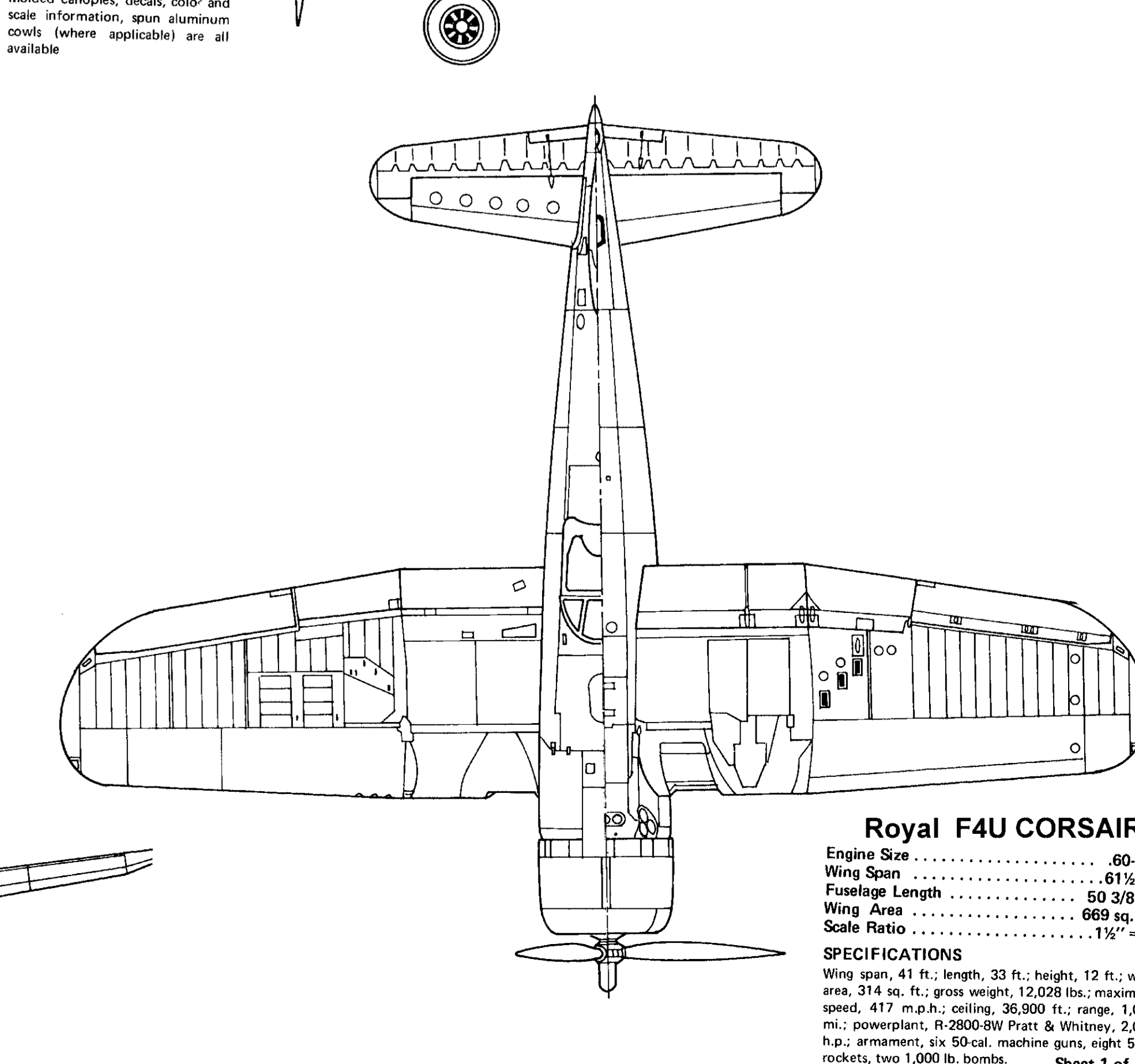

Sheet 1 of 1

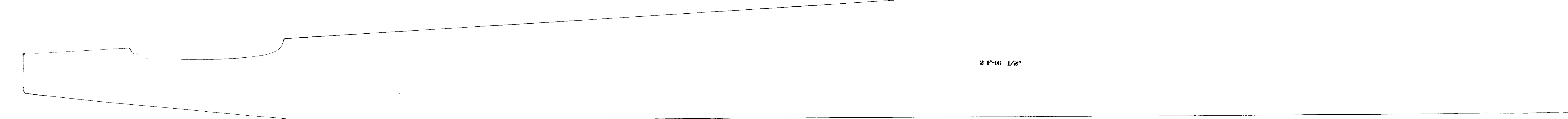
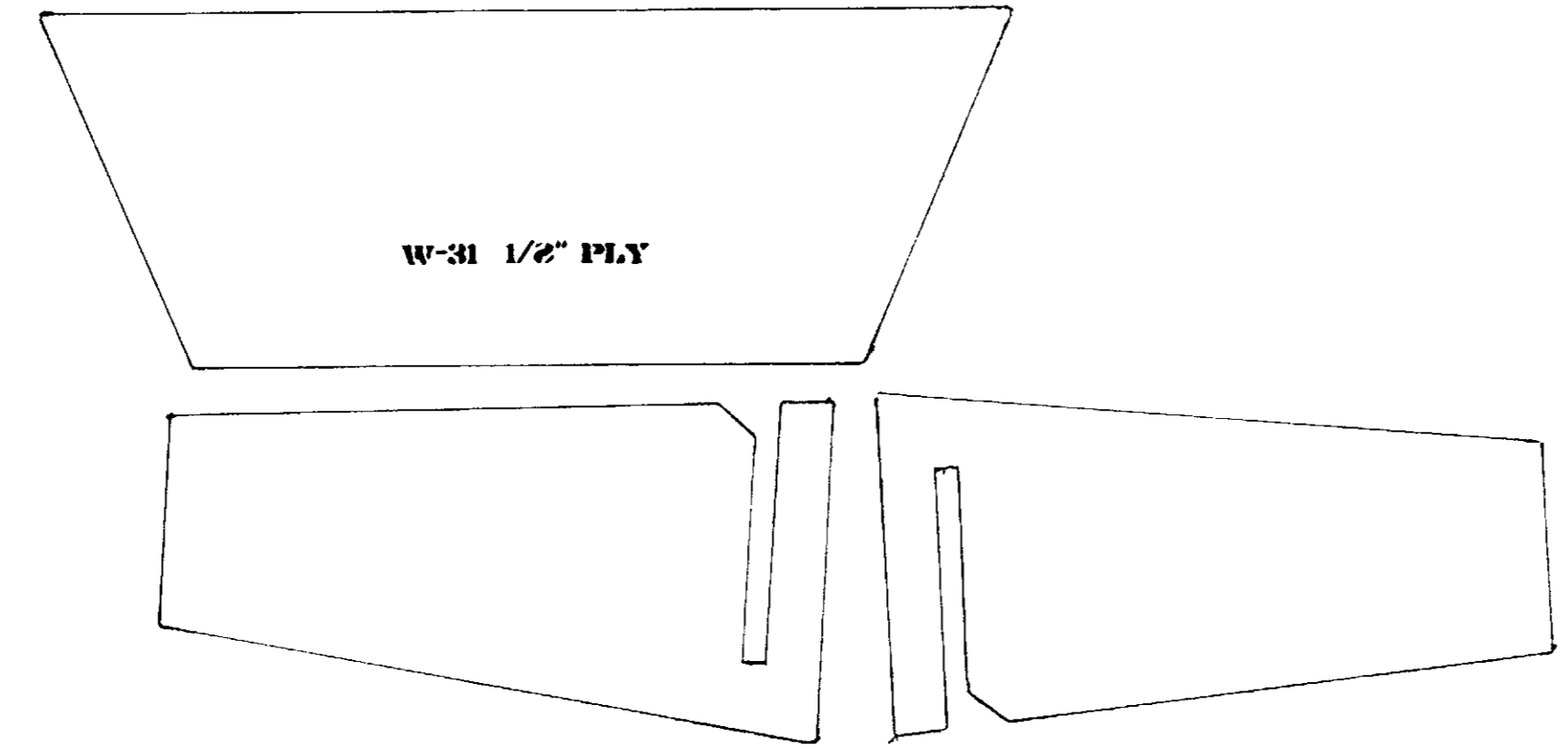
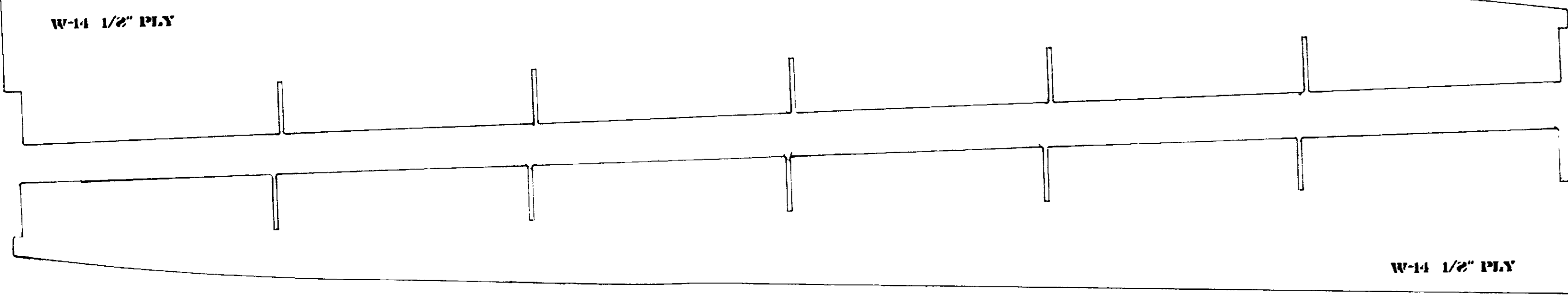

**ROYAL**  
**Corsair**  
Templates drawn by:  
Luke Zollner

