

H.L. Fish "Salmon"
 WINNER OF THE
1948 GOODYEAR TROPHY RACE
 FLYING THE COSMIC WIND
 SPEED 169.608 - 12 LAPS

THE [COSMIC WIND]

SPECIFICATIONS

WING SPAN 18 FT. 11 IN.
 LENGTH 17 FT. 0 IN.
 HEIGHT 4 FT. 5 IN.
 GROSS WEIGHT 850 POUNDS
 WING AREA 69 SQ. FT.
 WING LOADING . . . 12.3 LBS. / SQ. FT.
 POWER LOADING . . . 10 LBS. / H.P.
 TOP SPEED 200 M.P.H.
 ENGINE CONTINENTAL 85 H.P.
 FUEL CAPACITY 15 GALS.
 OIL CAPACITY 5 1/2 QTS.
 RANGE 425 MILES AT 150 M.P.H.
 COLOR - ALL NUMBERS, LETTERING, & SIDE STRIPES ARE CREAM THE REST IS INCA BRONZE.

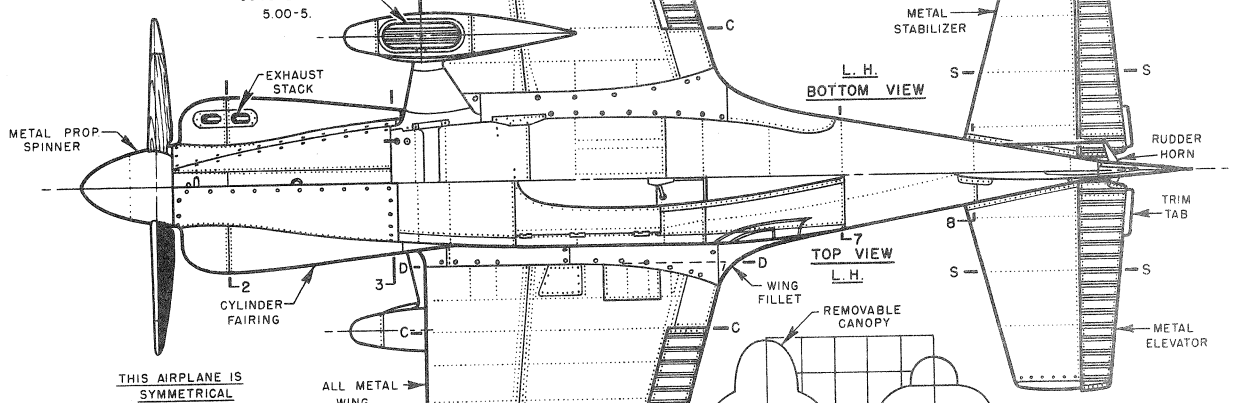
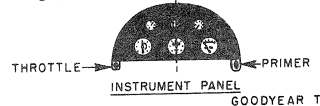
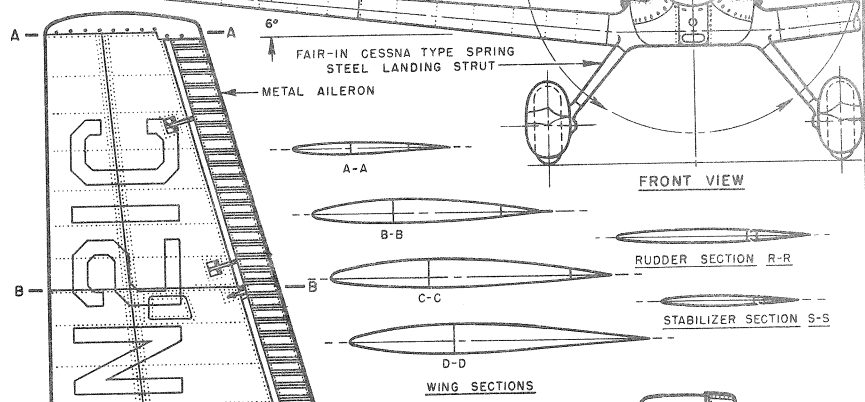
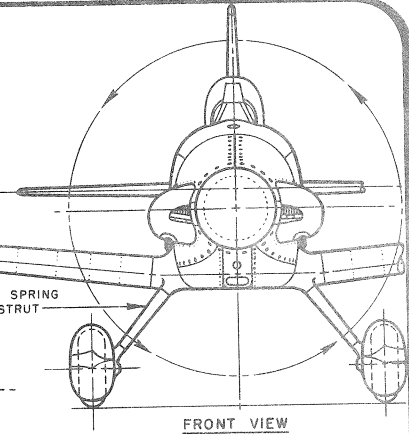
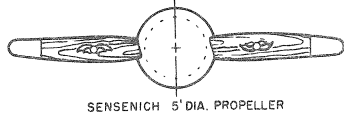

THIS AIRPLANE IS SYMMETRICAL

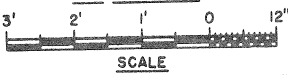
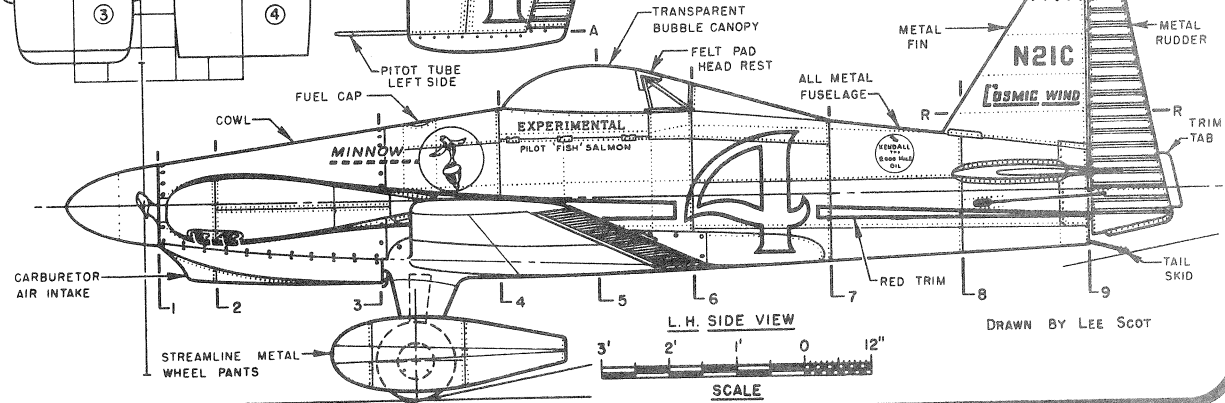
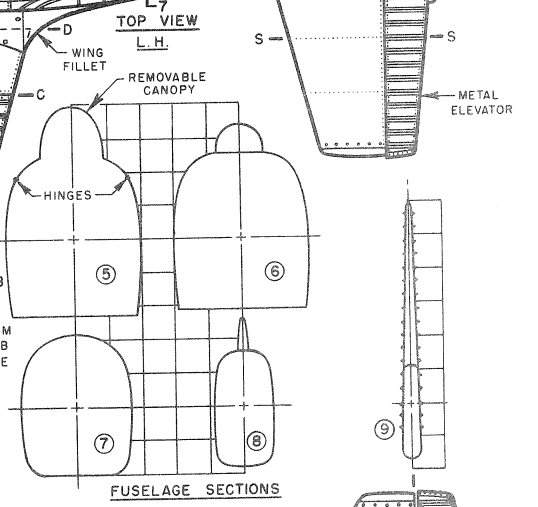
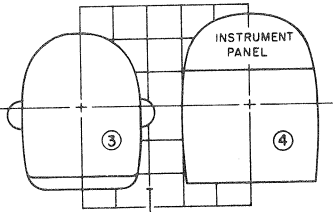
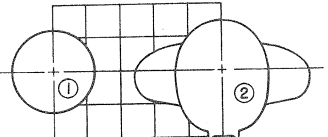

DRAWN BY LEE SCOT