

Dettaglio B
Le pulegge devono sporgere dai bordi del tavolo

Det. B
Pulleys shall lean out of the table border

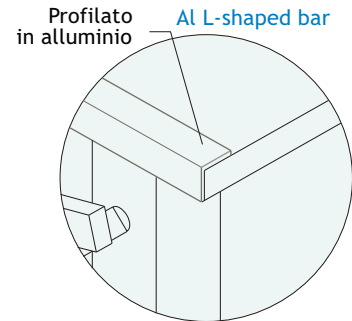

Dettaglio A **Detail A**

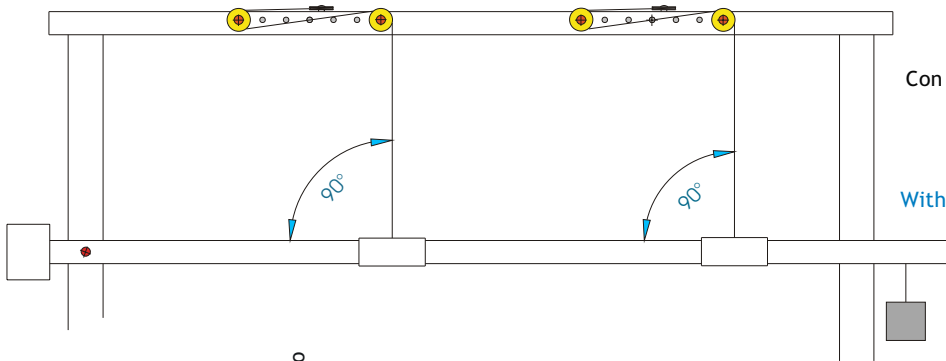

Messa a punto :
Con arco piazzato sulla mezziera delle dime, la barra di trascinamento deve risultare orizzontale

Set-up :
With cutting bow over both templates mid point, the traction bar must be horizontal

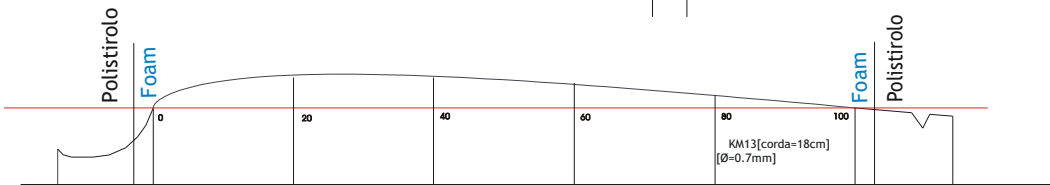

Dima per taglio estradosso
Upper profile template

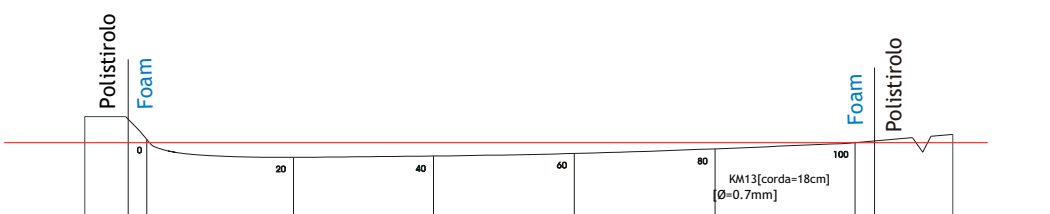

Dima per taglio intradosso
Lower profile template